

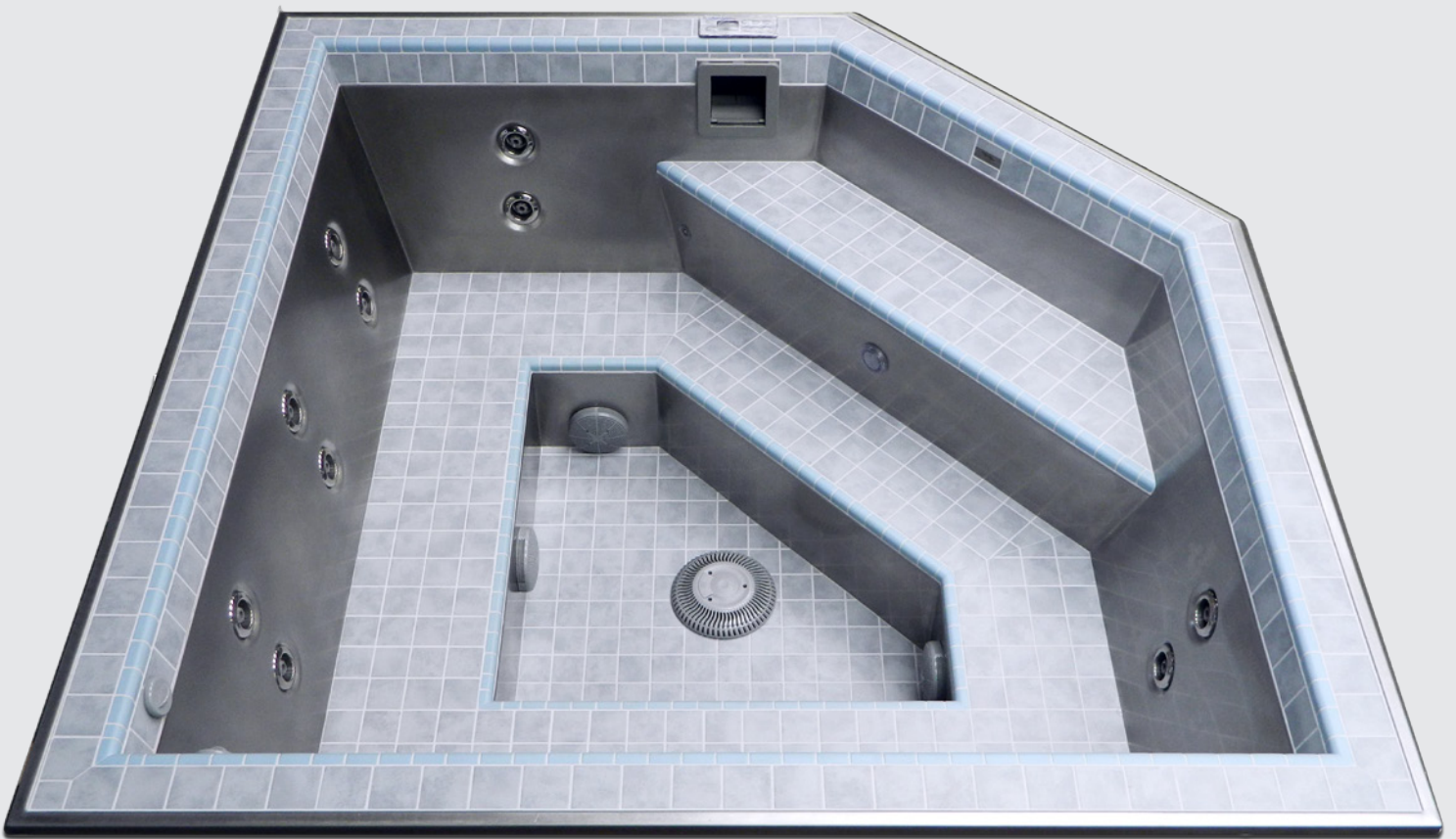

CLASSIC COLLECTION - TOPSAIL



AN UNCOMMON LUXURY THAT  
OUTLASTS AND OUTSHINES ANY  
ORDINARY SPA

## CLASSIC COLLECTION TOPSAIL 84" X 84"

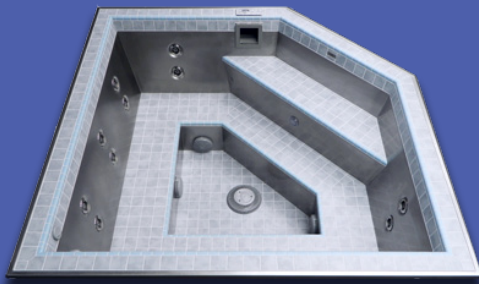

Bradford's Classic Collection of residential stainless steel spas arrive from our facility with all appropriate equipment. We provide frame-mounted equipment within the stainless steel frame or remote equipment on a lightweight, durable polypropylene platform. In-ground, recessed or on-grade final installations of a Bradford spa will require accessibility to the shell plumbing for the user. All electrical and plumbing must be performed by licensed trade contractors.

### ADDITIONAL OPTIONS

Ask Bradford about customizing your spa with one or many of our unique extras:

- |                  |                   |
|------------------|-------------------|
| Waterfalls       | Automatic Covers  |
| Infinity Edges   | Specialty Seating |
| Power Shower     | In-Spa Loungers   |
| Handrails        | Air Blowers       |
| LED Color Lights | Custom Finishes   |

|                                    |   |
|------------------------------------|---|
| Seating                            | 4-6 adults  |
| Dimensions                         | 84" x 84" x 41.5"   |
| Shell Material                     | 316L stainless steel (all stainless & tile trim); 304 stainless steel (full tile)   |
| Capacity                           | 375 gallons   |
| Weight                             | 610 lbs. dry; 3741 lbs. filled (tile trim model)  |
| Frame                              | Built-in integral 304 stainless steel   |
| Shell Insulation                   | High density urethane foam  |
| Jets                               | 16 commercial grade adjustable therapy jets   |
| Steps                              | 64" entry step; 10" tiled stair tread   |
| Seats                              | 13.5" wide bench seats on all sides   |
| Lighting                           | Low voltage underwater color wheel light  |
| Spa Cover                          | Deluxe insulated spa cover (excluded from shell only purchase)  |
| Finish Options                     | Tile trim: tile on floor; seats, steps, waterline & top lip; stainless steel walls<br>Stainless steel: non-directional buff finish on entire interior<br>Full tile: entirely tiled surface  |
| Remote Equipment or Frame Mounted: | BRD-300 with gas or electric heater (2 power supplies)<br>2 pump system (2 hp 2 speed & 1 speed)=30 amp GFI service<br>240V, 4 wire (2 hot, 1 neutral, 1 ground) to control circuit   |
| Frame Mounted Option               | BRD-250 Control or Similar (1 power supply)<br>2 pump (2 hp, 2 speed & 1 speed) w/ 5.5 kw heater=60 amp GFI service<br>240V, 4 wire (2 hot, 1 neutral, 1 ground) to control circuit   |
| Heater Options                     | 5.5 kw heater=30 amp GFI service-240V, 3 wire (2 hot, 1 ground) to heater<br>11 kw heater=60 amp GFI service-240V, 3 wire (2 hot, 1 ground) to heater<br>Gas=15 amp GFI service 120V, 3 wire (1 hot, 1 neutral, 1 ground) to heater |
| Equipment Platform Size            | 48" x 48" platform; 43" tall; 280 lbs. (2 pump system)  |
| Filter                             | 100 sq.ft. filtration system (remote equipment)   |
| Control System                     | Push button digital control panel   |
| Certifications                     | IAPMO certified<br>VGBA compliant<br>AWS certified welding  |
| Warranty                           | 25 year structural stainless steel shell; 5 year residential tile adhesion with approved tile; 1 year plumbing; 1 year electrical   |

### Elevation and Plan Drawings

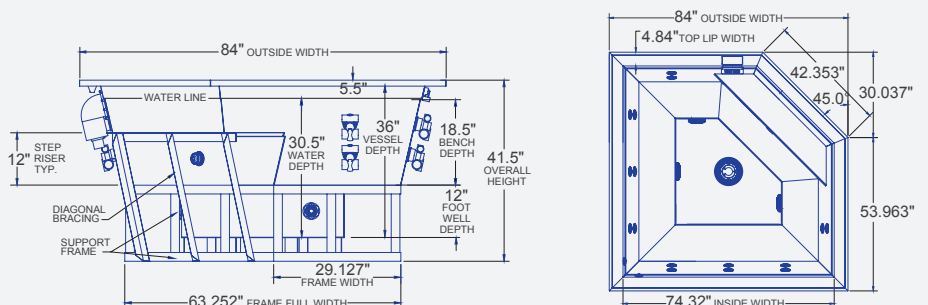

+1 800 438 1669 | 2101 ENTERPRISE DRIVE NE LELAND, NC 28451  
WWW.BRADFORDSPAS.COM | INFO@BRADFORDPRODUCTS.COM

keep up with our  
news and updates

